

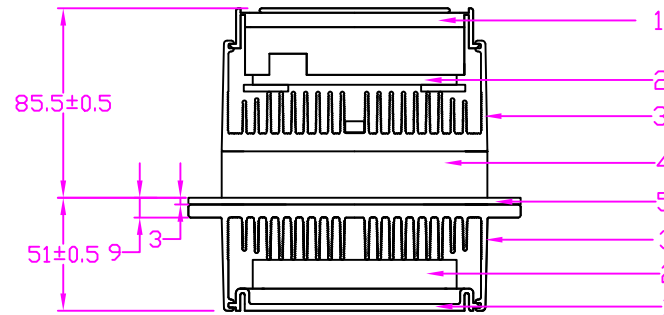

SPECIFICATIONS (Ta=32°C)	CODE #	DESCRIPTION
Heat Transfer Cold side	A	Air
Heat Transfer Warm side	A	Air
Cascade	-	
Cooling Effect	057	57 W at dT=0°C and Ta=32°C
Voltage Nominal	12	12 VDC (14,7 VDC MAX)
Current Nominal		5,9 A at dT=0°C
TE-Module(s)		PE-161-12-15 (2XP)
Fan(s) Cold side	2	12VDC, 0.23A, 92x92x20, MTBF 40.000 hrs L10
Fan(s) Warm side	2	12VDC, 0.25A, 92x92x25, MTBF 40.000 hrs L10
Thermostat / Regulation & Sensor	0	None
Thermostat Settings	0	None
Trimmable		
Accuracy & Hysteresis		
Thermostat Position & Casing	0	None ( Connections PC board on cold side heat sink)
Options: Protections	0	None
Rapid Cooling / Economy		None
Weight		2,9 kg net
Overheating Thermostat		75°C±5°C on warm side heat sink surface
Max. operating Temperature		54°C ambient
Enclosed		Mounting Screws(4X), Cable L= 1500
Packing		Individual cardboard



MOUNTING HOLE PRINT : 212 X 122

POS	ITEM No.:	DESCRIPTION	QTY	NOTE
1	Finger Guard	Plastics, warm black, cold grey	2	
2	Fan	Plastics	2	
3	Heat sink	Anodised Alu, cold silver, warm black	2	
4	Insulation	Polyurethane and Polyethylene	1	no CFC
5	Seal	Polyethylene, self-adhesive	1	flexible
6	Connector	± Input terminal (screws) on PC board	1	beneath finger guard

Qty/Product:	Material:	Project: Standard		
Designed by: Pavel Cech	Approved by / sign.: Hans Lindberg	Customer:	Date/Rev.No: S-99-06-06	Scale 1
		<b>COOLING-ASSEMBLY</b>		
Supercool AB Box 27, 40120 Göteborg, Sweden tel: +46 31 420530, fax: +46 31 247909 e-mail: pavel@supercool.se www.supercool.se		AA-057-12-22-00-00	SS-ISO2768-1	Sheet 1/1